

ATN PS31

NIGHT VISION GOGGLES



OPERATOR'S MANUAL (PS31) REVISION 1 – APRIL 2020

operator's manual

Important Export Restrictions! Commodities, products, technologies and services contained in this manual are subject to one or more of the export control laws and regulations of the U.S. Government and they fall under the control jurisdiction of either the US Department of State or the US BIS-Department of Commerce. It is unlawful and strictly prohibited to export, or attempt to export or otherwise transfer or sell any hardware or technical data or furnish any service to any foreign person, whether abroad or in the United States, for which a license or written approval of the U.S. Government is required, without first obtaining the required license or written approval from the Department of the U.S. Government having jurisdiction. Diversion contrary to U.S. law is prohibited.



**AMERICAN
TECHNOLOGIES
NETWORK
CORP.**

Register your product warranty online at
www.atncorp.com/warranty

SAFETY SUMMARY

CAUTIONS

- The ATN PS31 is a precision optical instrument and must be handled carefully at all times to prevent damage.
- Do not scratch the external lens surfaces or touch them with your fingers.
- To protect the image intensifier, keep the lens cap on the objective lens when the goggles is not in use or when checked out in daylight conditions.
- The IR illuminator is the light that is invisible to the unaided eye for use during conditions of extreme darkness. However, the light from the illuminator can be detected by others when using night vision devices.
- If you use the rubber eyecups for a long period of time, you may suffer skin inflammation. If you develop any symptoms, consult a doctor immediately.

WARNING

Do not carry batteries in pockets containing metal objects such as coins, keys, etc. Metal objects can cause the batteries to short circuit and become very hot.

The information in this manual is furnished for information use only, is subject to change without notice, is not to be construed as a commitment by ATN Corp.

ATN Corp. assumes no responsibility or liability for any errors or inaccuracies that may appear in this book.

© 2020 ATN Corp. All right reserved.

CAUTION:

**THIS PRODUCT CONTAINS NATURAL RUBBER LATEX WHICH MAY
CAUSE ALLERGIC REACTIONS.**

WARNING

Toxic Material

The image intensifier's phosphor screen contains toxic materials.

- If an image intensifier breaks, be extremely careful to avoid inhaling the phosphor screen material. Do not allow the material to come in contact with the mouth or open wounds on the skin.
- If the phosphor screen material contacts your skin, wash it off immediately with soap and water.
- If you inhale/swallow any phosphor screen material, drink a lot of water, induce vomiting, and seek medical attention as soon as possible.

WARNING

Do not use contaminated eyecup. They must be replaced.

WARNING

When installing the headmount over the protective mask, be careful not to break the protective mask seal around your face.

EQUIPMENT LIMITATIONS

To avoid physical and equipment damage when using the ATN PS31, carefully read and understand the following safety precautions.

- The equipment requires some night light (moonlight, starlight, etc.) to operate. The level of performance depends upon the level of light.
- Night light is reduced by passing cloud cover, while operating under trees, in building shadows, etc.
- The equipment is less effective viewing into shadows and other darkened areas.
- The equipment is less effective through rain, fog, sleet, snow or smoke.
- The equipment will not "see" through dense smoke.

NOTES

- **The purpose of the illuminator is to view at close distance up to 3 meters when additional illumination is needed.**

CAUTION

- **The ATN PS31 is a precision optical instrument and must be handled carefully at all times to prevent damage.**
- **Be careful when leaving the helmet mount in the flipped up position or removing the helmet mount from the helmet, damage can result.**

TABLE OF CONTENTS

	pg.		
SAFETY SUMMARY	a		
CHAPTER 1. INTRODUCTION	1-1		
1.1. General Information	1-2		
1.1.1. Scope	1-2		
1.1.2. Warranty Information	1-2		
1.1.3. Technical Information	1-2		
1.1.4. List of Abbreviations and Acronyms	1-3		
1.1.5. Glossary	1-4		
1.2. Equipment Description	1-6		
1.2.1. Equipment Characteristics, Capabilities, and Features	1-6		
1.2.2. Location and Description of Major Components	1-7		
1.2.3. Equipment Data	1-8		
1.3. Principles of Operation	1-10		
1.3.1. Mechanical Functions	1-10		
1.3.2. Optical Functions	1-10		
1.3.3. Electronic Circuit Function	1-10		
CHAPTER 2. OPERATING INSTRUCTIONS	2-1		
2.1. Description and Use of Operator's controls and indicators	2-2		
2.1.1. Operator Controls and Indicators	2-2		
2.2. Preventive Maintenance Checks and Services (PMCS)	2-4		
2.2.1. Preventive Maintenance Checks and Services Table	2-4		
2.2.2. Resolution Check Using the TS-4348/UV Test Set	2-11		
2.2.3. Inspection Criteria for Proper Image Intensifier Operation	2-13		
2.3. Assembly and Preparation for Use	2-18		
2.3.1. Unpacking	2-18		
2.3.2. Installation of Battery	2-18		
2.3.3. Installation of Eyecup	2-19		
2.3.4. Installation and Adjustment of Headmount	2-19		
2.3.5. Installation of Helmet Mount to Helmet	2-21		
2.4. Operating Procedures	2-23		
2.4.1. Hand-Held Operation	2-23		
2.4.2. Head Mounted Operation	2-24		
2.4.3. Helmet Mounted Operation	2-26		
2.4.4. IR Source Operations	2-29		
2.4.5. Preparation for Storage	2-31		
2.5. Operation under Unusual Conditions	2-32		
2.5.1. Operation in Dusty or Sandy Areas	2-32		
2.5.2. Operation in Rainy or Humid Conditions	2-32		
2.5.3. Operation in Salt Water Areas	2-33		
2.5.4. Operation in Nuclear, Biological and Chemical (NBC) Environments	2-33		
CHAPTER 3. MAINTENANCE INSTRUCTIONS	3-1		
3.1. Lubrication Instructions	3-2		
3.2. Troubleshooting Procedures	3-2		
3.2.1. Troubleshooting	3-2		
3.3. Operator's Maintenance Procedures	3-6		
3.3.1. Cleaning the NVG	3-6		

CHAPTER 1

INTRODUCTION

1.1. GENERAL INFORMATION

1.1.1. SCOPE

This manual provides operation and maintenance instructions for the Night Vision Goggles (NVG) ATN PS31 hereinafter referred to as the NVG. The NVG is a self-contained night vision device that enables improved night vision using ambient light from the night sky (moon, stars, skyglow, etc.).

Model Number and basic description

ATN PS31 — Night Vision Goggles

Supplier

American Technologies Network Corp.
1341 San Mateo Avenue
South San Francisco, CA 94080 USA

1.1.2. WARRANTY INFORMATION

This item shall conform to design, manufacturing, and performance requirements and be free from defects in material and workmanship for a period of two (2) years from the date of acceptance. If item is defective, notify ATN or point of purchase contact.

1.1.3. TECHNICAL INFORMATION

For technical information contact ATN Corp. directly at (650) 989-5100, or info@atncorp.com or your point of purchase contact.

TABLE 1.1. NOMENCLATURE CROSS-REFERENCE LIST

COMMON NAME	OFFICIAL NOMENCLATURE
Battery	Battery Nonrechargeable
Battery Cap	Cover Battery Retainer
Carrying Case	Case, Infrared Equipment
Carrying Case Strap	Strapping
Eyeiece Lens Cap	Cap, Protective, Dust
Headmount	Headset Assembly
Helmet Mount	Mount, Viewer
Goggles	Goggles Assy
Objective Lens Cap	Cap, Protective, Dust

1.1.4. LIST OF ABBREVIATIONS AND ACRONYMS

BII	Basic Issue Items
CAGEC	Commercial and Government Entity Code
cm	Centimeters
FM	Field Manual
Hrs	Hours
IR	Infrared
JTA	Joint Table of Allowances
lbs	Pounds
LED	Light Emitting Diode
NVG	Night Vision Goggles
MTOE	Modified Table of Organization and Equipment
N/A	Not Applicable
NBC	Nuclear, Biological, and Chemical
NSN	National Stock Number
Pam	Pamphlet
PASGT	Personal Armor System Ground Troops
PMCS	Preventive Maintenance Checks and Services
Qty	Quantity
Recm	Recommended
Rqr	Required
SF	Standard Form
TDA	Table of Distribution and Allowances-
TM	Technical Manual
TOE	Table of Organization and Equipment-
U/M	Unit of Measure
Vdc	Volts, direct current

1.1.5. GLOSSARY

BLACK SPOTS. These are cosmetic blemishes in the image intensifier of the NVG or dirt or debris between the lenses.

BRIGHT SPOTS. These defects can appear in the image area of the NVG. This condition is caused by a flaw in the film on the micro-channel plate. A bright spot is a small, nonuniform, bright area that may flicker or appear constant. Bright spots usually go away when the light is blocked out and are cosmetic blemishes that are signal induced.

CAUTION. Condition, practices, or procedures that must be observed to avoid damage to equipment, destruction of equipment, or a long-term health hazard.

CHICKEN WIRE. An irregular pattern of dark thin lines in the field-of-view either throughout the image area or in parts of the image area. Under the worst case condition, these lines will form hexagonal or square-wave shaped lines.

DARK (OR DARK AREA). A place in which there is very little light. It does not mean total darkness. Generally, this means conditions similar to a quarter-moon or starlit night.

DARK-ADAPTED. Having ones eye adjusted to the goggles's output under low light conditions.

DIOPTER. A unit of measure used to define eye correction. Adjustments to the diopter adjustment will provide a clearer image in each eye.

EDGE GLOW. This is a defect in the image area of the goggles. Edge glow is a bright area (sometimes sparkling) in the outer portion of the viewing area.

EMISSION POINT. A steady or fluctuating pinpoint of bright light in the image area and does not go away when all light is blocked from the objective lens of the goggles. The position of an emission point within the image area of the goggles does not move. An emission point should not be confused with a point light source in the distance.

FIXED-PATTERN NOISE. This is a cosmetic blemish in the image area characterized by a faint hexagonal (honeycomb) pattern throughout the viewing area that most often occurs at high light levels or when viewing very bright lights. Fixed-pattern noise is inherent in the structure of the fiber optics and can be seen in every image intensifier if the light level is high enough.

FLASHING. This is a defect in the image area of the goggles. The image appears to flicker or flash.

FLICKERING. See "flashing."

GAIN. This is the number of times a night vision device amplifies light input.

IMAGE INTENSIFIER. An electro-optical device that detects and amplifies ambient light to produce a visual image.

INFINITY FOCUS. Adjustment of the objective lens so that a distant object, such as a star or the point light on a distant tower, forms the sharpest image.

INTERMITTENT OPERATION. This is a defect in the image area of the goggles. See "flashing".

IR SOURCE. This is an IR Light Emitting Diode (LED). When turned on, the IR source provides additional illumination to enhance existing light conditions used only for performing nearby tasks.

MICROCHANNEL PLATE. A current-multiplying optical disk that intensifies the electron image produced by the photocathode.

NOTE. Essential information of special importance, interest, or aid in job performance.

PHOTOCATHODE. The input optic of an image intensifier that absorbs light energy and in turn releases electrical energy in the form of an electron image.

SCINTILLATION. A faint, random, sparkling effect throughout the image area. Scintillation is a normal characteristic of the image intensifier and should not be confused with emission points. Scintillation is more pronounced under low light conditions. Also called "video noise".

SHADING. The viewed image should be a full circle. If shading is present, you will not see a fully circular image. Shading is indicative of a dying photocathode and is caused by a defective vacuum seal of the image intensifier. Shading is very dark and you cannot see an image through it.

WARNING. Conditions, practices, or procedures that must be observed to avoid personal injury or loss of life.

1.2. EQUIPMENT DESCRIPTION

1.2.1. EQUIPMENT CHARACTERISTICS, CAPABILITIES, AND FEATURES

The NVG is a hand-held, headmounted, helmet mounted night vision system that enables walking, weapon firing, short-range surveillance, map reading, vehicle maintenance, and administering first aid in both moonlight and starlight. Each unit allows for vertical adjustment, fore-and-aft adjustment, objective lens focus and eyepiece focus. The goggles is also equipped with an IR source.



FIGURE 1.1. COMPONENTS OF NVG

1.2.2. LOCATION AND DESCRIPTION OF MAJOR COMPONENTS

The NVG includes the items shown in Figure 1.1. The major components are the headmount, helmet mount, goggles, carrying case.

a. Goggles

The goggles (see Figure 1.2.) consists of various components such as an objective lens, an image intensifier (not shown), an eyepiece lens and a battery cap.

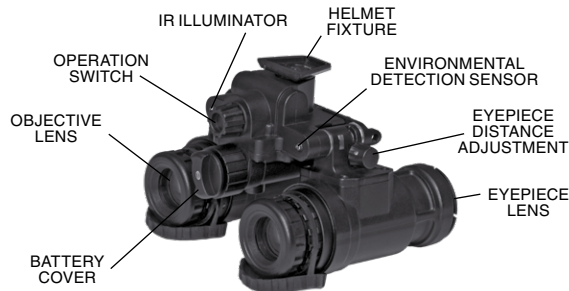

FIGURE 1.2. NIGHT VISION GOGGLES

b. Headmount (Optional)

The headmount (Figure 1.1.) secures the goggles to the operator's head for night viewing and provides freehand support for use with a weapon, protective mask or other purposes. It is adjustable and cushioned.

c. Helmet Mount

This item (Figure 1.1.), secures the goggles to the Personal Armor System Ground Troops (PASGT) helmet allowing freehand support for use with a weapon, protective mask and/or other purposes.

f. Carrying Case

The carrying case (Figure 1.1.) is provided for transportation and protection of the goggles, headmount, battery and accessories. Two slide keepers are provided for belt attachment and three D-rings for shoulder and leg strap attachment. A carrying case strap is also provided which can be attached to the two D-rings on the back of the carrying case.

1.2.3. EQUIPMENT DATA

The following tables provide information pertaining to the operational, electrical, mechanical, optical, and environmental characteristics for the goggles.

TABLE 1.2. OPERATOR ADJUSTMENT LIMITS

ITEM	LIMITS
Diopter Focus	+5 to -5 diopters
Objective Focus	25 cm to infinity

TABLE 1.3. ELECTRICAL DATA

ITEM	DATA
Battery Requirements	Lithium battery (CR123x1) / CR123x4 external battery holder

TABLE 1.4. MECHANICAL DATA

ITEM	CHARACTERISTICS
Carrying Case	Size: Approx. 14" x 8"
Goggles (see Note)	Weight: 560 grams

NOTE

Weight of the goggles does not include accessories.

TABLE 1.5. OPTICAL DATA

ITEM	DATA
Magnification	1.0x
Field-of-View	50 deg +/-2 deg
Diopter Focus	+5 to -5 diopters
Objective Focus	25 cm to infinity

TABLE 1.6. ENVIRONMENTAL DATA

ITEM	DATA
Goggles Operating Temperature	-51°C to +49°C
Goggles Storage Temperature	-51°C to +85°C
Illumination Required	Overcast starlight to moonlight

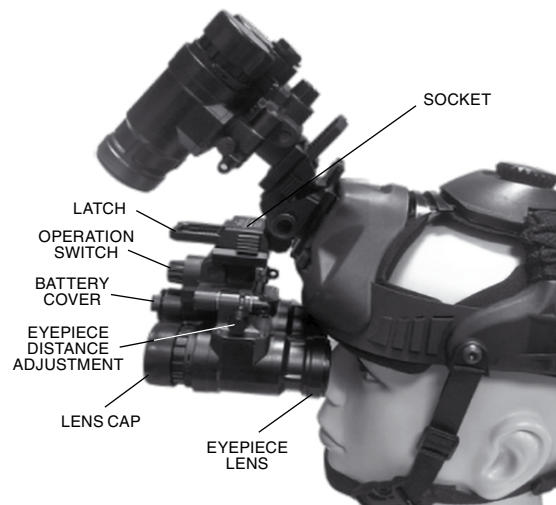

FIGURE 1.3. MECHANICAL FUNCTIONS FOR THE NVG.

1.3. PRINCIPLES OF OPERATION

1.3.1. MECHANICAL FUNCTIONS

The mechanical functions of the NVG allow for differences in the physical features of individual operators and provide for operating the system. These functions include the power switch, eye relief adjustment, diopter adjustment, and objective focus. The mechanical controls are identified in Figure 1.3.

1.3.2. OPTICAL FUNCTIONS

The optical functions include an objective lens, image intensifier and eyepiece lens (Figure 1.4.). The objective lens collects light reflected from the night scene by the moon, stars, or night sky, inverts the image and focuses that image on the image intensifier. The image intensifier converts the captured light into a visible image and reinverts the image which can then be viewed through the eyepiece lens.

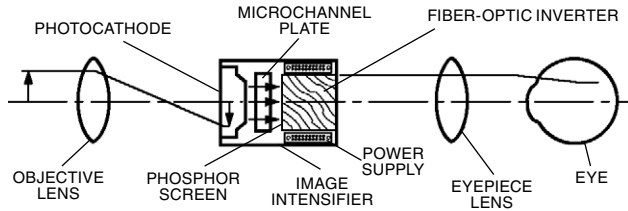

FIGURE 1.4. OPTICAL FUNCTION DIAGRAM

1.3.3. ELECTRONIC CIRCUIT FUNCTION

The electronic circuit regulates the direct current voltage from the battery to the image intensifier and IR source as required. It also monitors the output voltage of the battery and turns on a low-battery indicator when the available battery voltage is 1.9–2.1 Vdc.

a. Power Source

The electronic circuit is powered by one battery.

b. Auto Mode

The automatic mode is different from the “IR” mode, and the automatic mode starts the environment detection sensor. It can detect environmental luminance in real time and work with reference to the illumination control system. Under extremely low or extremely dark environment, The system will automatically turn on infrared auxiliary lighting, and when the environmental illumination can meet normal observation, The system automatically turns off “IR”, and when the ambient illumination reaches 40–100 Lux, The whole system is automatically shut down to protect the photosensitive core components from damage by strong light.

CHAPTER 2

OPERATING INSTRUCTIONS

2.1. DESCRIPTION AND USE OF OPERATOR'S CONTROLS AND INDICATORS

NOTE

The NVG is a precision electro-optical instrument, so handle it carefully. If the equipment fails to operate, refer to the Troubleshooting Procedures in Chapter 3.

2.1.1. OPERATOR CONTROLS AND INDICATORS

The NVG is designed to adjust for different users and corrects for most differences in eyesight. The controls and indicators for the NVG are shown in Figure 2.1., which are described in Table 2.1.

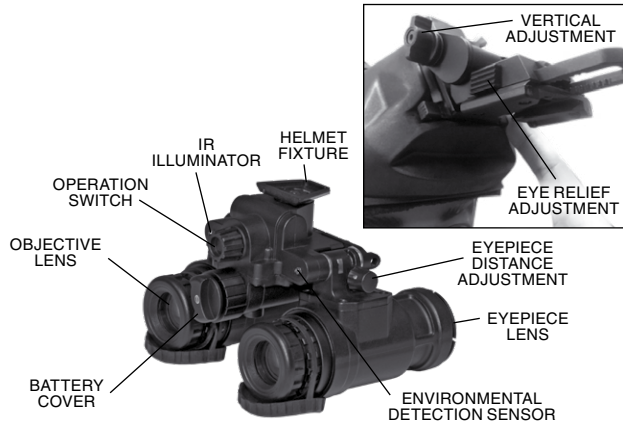

FIGURE 2.1. GOGGLES CONTROLS AND INDICATORS

NOTE

Low battery indicator and IR source “ON” indicator are visible in eyepiece lens.

TABLE 2.1. GOGGLES CONTROLS AND INDICATORS

CONTROLS AND INDICATORS		FUNCTIONS
Power Switch	OFF	Turns OFF the NVGs.
	ON	Goggles activated.
	IR	Turn On IR Illuminator.
	Auto	Automatic Environment Detection mode.
Objective Lens	Focuses objective lens. Adjusts for sharpest image of viewed object.	
Diopter Adjustment	Focuses eyepiece lens for use without the need for glasses. Adjust for sharpest image of intensifier screen.	
Eye Relief Adjustment	Adjusts the distance between your eye and the goggles.	
Latch	Latch used for separation of goggles from head-mount/helmet mount.	
Battery Polarity Indicators	This feature, molded into the battery housing, shows the proper orientation of the battery. Some versions have a bubble molded into the top of the battery house, to show the + for proper orientation.	

2.2. PREVENTIVE MAINTENANCE CHECKS AND SERVICES (PMCS)

2.2.1. PREVENTIVE MAINTENANCE CHECKS AND SERVICES TABLE

a. General

To ensure the readiness of the NVG, perform the preventive maintenance procedures in accordance with Table 2.2., prior to each mission. Preventive maintenance procedures include inspection, cleaning, and performance of the checkout procedures.

b. Warnings and Cautions

Always observe the WARNINGS and CAUTIONS appearing in the table. Warnings and cautions appear before applicable procedures. You must observe the warnings and cautions to prevent serious injury to yourself and others, or to prevent your equipment from being damaged.

c. Explanation of Table Entries

(1) Item Number Column. Numbers in this column are for reference. When completing Equipment Inspection and Maintenance Worksheet, include the item number for the check/service indicating a fault. Item numbers also appear in the order that you must do checks and services for the intervals listed.

(2) Interval Column. This column tells you when you must do the procedure in the procedure column. BEFORE procedures must be done before you operate or use the equipment for its intended mission. DURING procedures must be done during the time you are operating or using the equipment for its intended mission. AFTER procedures must be done immediately after you have operated or used the equipment.

(3) Location, Check/Service Column. This column provides the location and the item to be checked or serviced. The item location is underlined.

(4) Procedure Column. This column gives the procedure you must do to check or service the item listed in the Check/Service column to know if the equipment is ready or available for its intended mission or operation. You must do the procedure at the time stated in the interval column.

(5) Not Fully Mission Capable If: Column. Information in this column tells you what faults will keep your equipment from being capable of performing its primary mission. If you make check and service procedures that show faults listed in this column, do not operate the equipment. Follow standard operating procedures for maintaining the equipment or reporting equipment failure.

d. Other Table Entries

Be sure to observe all special information and notes that appear in your table.

TABLE 2.2. PREVENTIVE MAINTENANCE CHECKS AND SERVICES FOR THE NVG.

ITEM NO.	INTER-VAL	LOCATION CHECK/SERVICE	PROCEDURE	NOT FULLY MISSION CAPABLE IF:
1	Before		Open carrying case and check the inventory items	
2	Before/After	Goggles Optical Surfaces	Inspect all lenses (objective, eyepiece, IR lens and high light cut-off window) for dirt, fingerprint residue, chips, or cracks. If necessary, clean and dry lenses with water and lens tissue.	Scratches or heavy scratches that hinder vision with goggles turned ON, or if cracks are present.
3	Before/After	Battery Cap Housing	Inspect external surfaces for cracks or damage. Scratches, cracks, and gouges are OK if operation is not affected. Inspect battery compartment. Check to make sure battery cap is present. Remove battery cap and inspect for moisture, cracks, corroded or defective spring contacts, and o-ring present in cap.	Cracks or damage in the battery housing. Cap is missing, contacts damaged, or corroded, o-ring is missing.

ITEM NO.	INTER-VAL	LOCATION CHECK/SERVICE	PROCEDURE	NOT FULLY MISSION CAPABLE IF:
3. Cont.	Before/After	Battery Cap/Housing Cont.	Remove battery and turn the power switch from Off to ON to AT. Each position should have a definite stopping point. Inspect for broken or missing knob. Install battery and check IR source functions. Check the high light cut-off with daylight or bright room light (not fluorescent light) by placing the lens cap on the objective lens. Turn goggles ON and observe that the system cuts OFF within 70 ±30 seconds.	Power switch has no definite stopping points or knob is broken or missing. IR source does not work. If damaged, refer to higher level of maintenance.
3. Cont.	Before/After	Battery Cap/Housing Cont.	Turn goggles OFF and then ON to reenergize goggles. NOTE If the goggles fails this highlight cut-off test, it does not cause the end item to be nonmission capable. However, it should be sent to higher level of maintenance as soon as possible.	

ITEM NO.	INTER-VAL	LOCATION CHECK/SERVICE	PROCEDURE	NOT FULLY MISSION CAPABLE IF:
4	Before/ After	Goggles	Inspect for cracks or damage. Scratches, cracks, chips and gouges are OK if operation is not affected.	Cracks or damage in the goggles.
5	Before/ After	Eyeiece Lens	Rotate diopter adjustment to make sure the eyepiece lens moves freely and is not loose. Range is approximately ½ turn.	Binding, not moving freely or too loose.
6	Before/ After	Eyecup	Inspect for dirt, dust, cracked or torn eyecup. Inspect for bent, broken, or improperly fitting eyepiece lens. If necessary, clean with water.	Chips and cracks are permitted on the eyecup retaining rings as long as they do not interfere with installation of eyecup.
7	Before/ After	Objective Lens	Rotate focus ring to ensure free movement (range is approximately 1/3 turn). Check objective lens for chips, cracks and dents.	Focus ring is binding or not able to move.

ITEM NO.	INTER-VAL	LOCATION CHECK/SERVICE	PROCEDURE	NOT FULLY MISSION CAPABLE IF:
8	Before/ After	Viewed Image	NOTE Operator may use the TS-4348/UV to check resolution (paragraph 2.2.2). Refer to paragraph 2.2.3. to inspect for operational defects.	Flickering, flashing, edge glow, or shading is observed.
9	Before/ After	Socket	Inspect for dirt, dust, or corrosion. Insert goggles latch into socket to verify secure attachment of goggles to helmet mount. If necessary, clean socket with water.	Damaged, latch won't lock or is too loose.
10	Before/ After	Eye Relief Adjustment	Press the eye relief adjustment and check for free motion. Inspect for damage.	Binding, damaged or non-operational slide mechanism.
11	Before/ After	HELMET MOUNT Straps	Inspect for cuts, tears, fraying, holes, cracks, or defective fasteners.	Damage causes straps to be unserviceable.

ITEM INTER-VAL NO.		LOCATION CHECK/SERVICE	PROCEDURE	NOT FULLY MISSION CAPABLE IF:
12	Before/ After	Fore-and-Aft Adjustment	Press the 2 side buttons on plastic mount or depress side lever on metal mount and check for free motion. Inspect for damage.	Binding, damaged or non-operational slide mechanism.
13	Before/ After	<u>MOUNTING ADAPTERS</u> Headmount/ Helmet Mount	Inspect for dirt, dust or corrosion. Insert into headmount or helmet mount socket to verify secure attachment.	Damaged, will not latch securely.
14	Before/ After	<u>CARRYING CASE</u> Case	Remove all items and shake out loose dirt or foreign material. Inspect for tears, cuts, excess wear, or damage to mounting clips.	

2.2.2. RESOLUTION CHECK USING THE TS-4348/UV TEST SET

NOTE

The TS-4348/UV Test Set can be used by the operator to check the resolution of a goggles at any time.

NOTE

The TS-4348/UV Test Set can be used by Direct Support/Intermediate Level to perform the resolution testing 180 Day Service. If a system fails it must be tested on the TS-3895A/UV Test Set.

NOTE

Verify the resolution of the goggles using the TS-4348/UV Test Set at every opportunity. The resolution cannot be accurately measured without the test set.

The following procedures are designed to check the performance of the image intensifier.

a. Setup

Before using the TS-4348/UV Test Set to set up and familiarize yourself with its operation and the warnings and cautions associated with that test equipment.

NOTE

- The resolution test must be performed in a darkened area. Your eyes must be dark-adapted to perform this test. Review the following test procedure before entering the dark area.
- Expect cosmetic blemishes, such as chicken wire, black spots, and fixed-pattern noise, to stand out while viewing through the TS-4348/UV Test Set when it is on the high light level. This is acceptable.
- The rejection of any NVG for cosmetic defects must be based on an outdoor evaluation and not the TS-4348/UV Test Set.

b. Low Light and High Light Resolution Test Procedure

Test the goggles for low light and high light resolution performance according to the following steps.

- (1) Place the HIGH/LOW switch on the test set to the LOW position.

- (2) Turn off the room light and let your eyes adjust to the dark.
- (3) Turn on the test set by setting the “OFF” switch to the “ON” position.
- (4) Turn on the goggles and insert it into the test port on the test set.
- (5) Look through the goggles and view the projected pattern (see Figure 2.2.). If necessary, focus the eyepiece lens and then the objective lens to obtain the sharpest image.
- (6) The NVG goggles must be able to resolve Group 2, Element 2, under low light conditions to pass the test. If the NVG does not pass the test, return it to maintenance for repair. The operator must document resolution failures on the maintenance record.

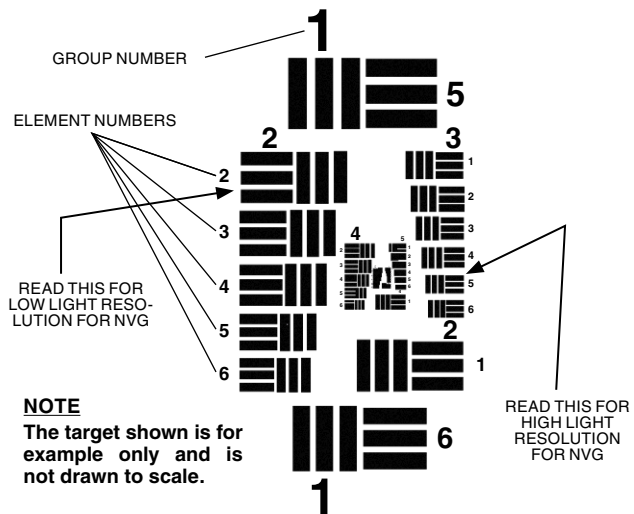

FIGURE 2.2. TS-4348/UV TEST SET PATTERN

NOTE

For a pattern to be resolvable, three vertical bars and three horizontal bars must be visible.

- (7) Flip the HIGH/LOW switch to the HIGH position.
- (8) Again, look through the goggles and view the projected pattern (see Figure 2.2.). If necessary, refocus the objective lens and then the eyepiece lens to obtain the sharpest image.
- (9) The NVG must be able to resolve Group 3, Element 5, under high light conditions to pass the test. If the goggles does not pass the test, send it to a higher level of maintenance for repair.

NOTE

When using the TS-4348/UV Test Set, you are not viewing the entire image intensifier. Therefore, operational and cosmetic inspections must be done without the test set as specified in paragraph 2.2.3.

- (10) Look for flashing, flickering, or other nonstable behavior of the image intensifier. Also check the image intensifier for other operational defects described in paragraph 2.2.3. To view the image intensifier under low light conditions, flip the HIGH/LOW switch to the LOW position and allow your eyes to become accustomed to the dark. If any unacceptable conditions are noted, send to a higher level of maintenance for repair.

2.2.3. INSPECTION CRITERIA FOR PROPER IMAGE INTENSIFIER OPERATION

a. General

As directed in the Preventive Maintenance Checks and Services table, image intensifier operation must be checked before each mission. This section provides information for the operator concerning what to look for, how to look for it, and how to determine if the NVG should be returned to the maintainer.

CAUTION

Perform the following inspection in the dark.

To perform this inspection, attach the goggles to the headmount and turn the power switch to the ON position. Look through the goggles and view the image.

There are two groups of “defects” you may encounter — operational defects and cosmetic blemishes. Operational defects are an immediate cause to reject the NVG. Cosmetic blemishes are not a cause for rejection unless they become severe enough to interfere with the ability to perform the mission. **The rejection of any NVG for cosmetic defects must be based on an outdoor evaluation and not the TS-4348/UV Test Set.**

b. Operational Defects

These defects relate to the reliability of the image intensifier and are an indication of instability. If identified, they are an immediate cause for rejecting the NVG. They include shading, edge glow, flashing, flickering, and intermittent operation.

(1) Shading. If shading is present, you will not see a fully circular image (see Figure 2.3.). Shading is very dark and you cannot see an image through it. Shading always begins on the edge and migrates inward eventually across the entire image area. Shading is a high contrast area with a distinct line of demarcation. Return the NVG to the maintainer.

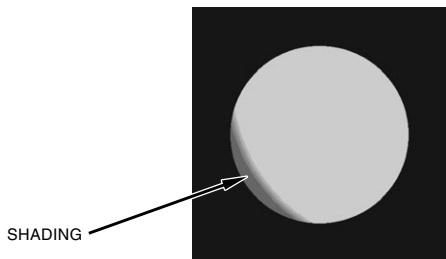

FIGURE 2.3. SHADING

NOTE

Make sure the shading is not the result of improper eye-relief adjustment (refer to paragraph 2.4.2.).

(2) Edge Glow. Edge glow is a bright area (sometimes sparkling) in the outer portion of the viewing area (see Figure 2.4.).

To check for edge glow, block out all light by cupping a hand over the objective lens. If the image intensifier is displaying edge glow the bright area will still show up. Return the NVG to the maintainer.

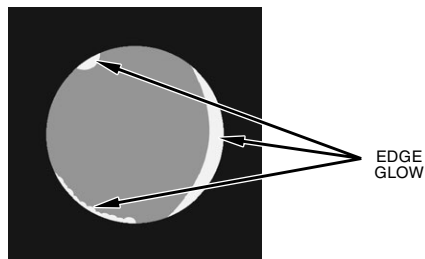

FIGURE 2.4. EDGE GLOW

(3) Flashing, Flickering, or Intermittent Operation. The image may appear to flicker or flash. If there is more than one flicker, check for loose battery cap or weak battery. If weak or loose batteries are not the problem return the NVG to the maintainer.

c. Cosmetic Blemishes

These are usually the result of manufacturing imperfections that do not affect intensifier reliability and are not normally a cause for rejecting an NVG. However, some types of blemishes can get worse over time and interfere with the ability to perform the mission. If you believe a blemish is cause for rejection, record the specific nature of the problem on the maintenance forms and identify the position of the blemish by using the clock method and approximate distance from the center (e.g., 5 o'clock toward the outside, 2:30 near the center, or 1:00 midway). The following are cosmetic blemishes:

(1) Bright Spots. A bright spot is a small, nonuniform, bright area that may flicker or appear constant (Figure 2.5.). Not all bright spots make the NVG rejectable. Cup your hand over the objective lens to block out all light. If the bright spot remains, return the NVG to the maintainer. Bright spots usually go away when the light is blocked out. Make sure any bright spot is not simply a bright area in the

scene you are viewing. **Bright spots are acceptable if they do not interfere with the operator's ability to view the image or to perform the mission.**

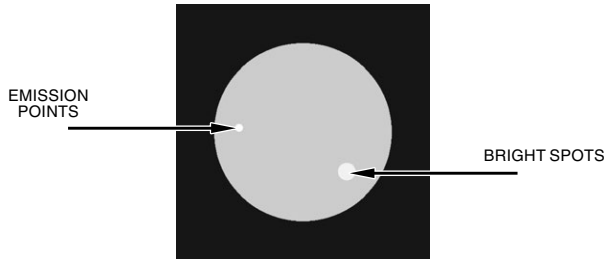

FIGURE 2.5. BRIGHT SPOTS AND EMISSION POINTS

(2) Emission Points. A steady or fluctuating pinpoint of bright light in image area that does not go away when all light is blocked from the objective lens of the goggles (Figure 2.5.). The position of an emission point within the image area does not move.

Not all emission points make the NVG rejectable. Make sure any emission point is not simply a point light source in the scene you are viewing. **Emission points are acceptable if they do not interfere with the operator's ability to view the image or to perform the mission.**

(3) Black Spots. These are cosmetic blemishes in the image intensifier or dirt or debris between the lenses. Black spots are acceptable as long as they do not interfere with viewing the image. **No action is required if this condition is present unless the spots interfere with the operator's ability to view the image or to perform the mission.**

(4) Fixed-Pattern Noise. This is usually a cosmetic blemish characterized by a faint hexagonal (honeycomb) pattern throughout the viewing area that most often occurs at high light levels or when viewing very bright lights (see Figure 2.6.). This pattern can be seen in every image intensifier if the light level is high enough. **This**

condition is acceptable as long as the pattern does not interfere with the operator's ability to view the image or to perform the mission.

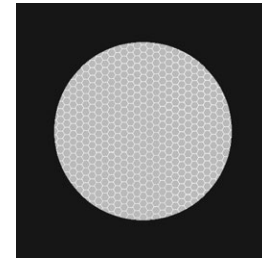

FIGURE 2.6. FIXED-PATTERN NOISE

(5) Chicken Wire. An irregular pattern of dark thin lines in the field-of-view either throughout the image or in parts of the image area (see Figure 2.7.). Under the worst case condition, these lines will form hexagonal or square-wave shaped lines. **No action is required if this condition is present unless it interferes with the operator's ability to view the image or to perform the mission.**

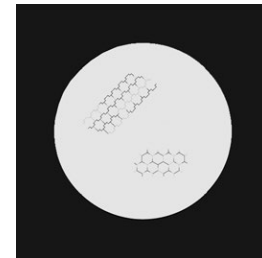

FIGURE 2.7. CHICKEN WIRE

2.3. ASSEMBLY AND PREPARATION FOR USE

2.3.1. UNPACKING

The following steps must be accomplished prior to each mission where the NVG is used.

- (1) Check contents for completeness (see Figure 1.1.).
- (2) Remove carrying case. Open carrying case (Figure 1.1.), remove NVG, and check contents for completeness.
- (3) Inspect the goggles for obvious evidence of damage to optical surfaces, body, eyecup, power switch, battery cap, etc. Ensure that all optical surfaces are clean and ready for use. Clean with lens paper.

2.3.2. INSTALLATION OF BATTERY

CAUTION

To protect the image intensifier, keep the objective lens cap on when the goggles are not in use or when using the goggles in daylight conditions.

The NVG operates with one CR123 battery.

TABLE 2.3. ESTIMATED BATTERY LIFE

BATTERY TYPE	TEMPERATURE	NEGLIGIBLE IR SOURCE USAGE	IR SOURCE USAGE 10% OF THE TIME
CR123	21°C (70°F)	60 Hrs	55 Hrs

CAUTION

- Make certain the power switch is in the OFF position before installing the battery.

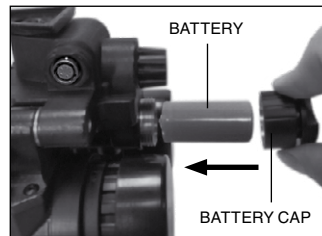

FIGURE 2.8. INSTALLATION OF BATTERY

Install the CR123 battery into the PS31 as follows.

- (1) Unscrew the battery cap.
- (2) Observe polarity, as indicated on the side of the battery compartment and insert the battery.
- (3) Replace the battery cap and screw cap hand tight.

2.3.3. INSTALLATION OF EYECUP

Perform the following procedure to install eyecup onto the goggles. Refer to Figure 2.1.

- (1) Carefully press the eyecup over the end of the eyepiece lens.
- (2) Rotate the eyecup into proper viewing position. Adjust for best fit. The eyecup must seal around your eye and prevent the green glow from escaping.

2.3.4. INSTALLATION AND ADJUSTMENT OF HEADMOUNT

Perform the following procedures for donning the headmount.

NOTE

Do not don the headmount while the goggles are attached.

- (1) Prior to donning the headmount, loosen the four ends of the chinstrap approximately two inches from the sliding bar buckles.
- (2) Snap the front and rear snaps in place.
- (3) With both hands grasp the neck pad and pull the harness over your head and the neck pad down to the back of your neck.
- (4) Holding the chin cup in position on chin, adjust both sides of the chinstrap until you feel light pressure against your chin. (DO NOT TIGHTEN.)
- (5) Maintain the position of the chin cup and remove any slack from the chinstrap. (DO NOT TIGHTEN.)

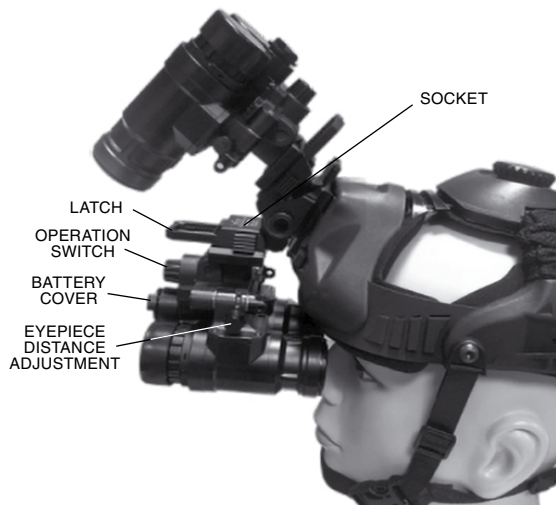

FIGURE 2.9. NVG HEADMOUNT ADJUSTMENTS

- (6) Ensure that the cross-strap is not twisted and remove slack by adjusting the vertical adjustment at the neck pad.

- (7) Adjust chinstrap and vertical adjustment until the chin cup and headband are in a comfortable but firm position.

NOTE

After installing the goggles, minor strap adjustments may be necessary to achieve comfort.

- (8) Refer to paragraph 2.4.2. for operating procedures.

2.3.5. INSTALLATION OF HELMET MOUNT TO HELMET

- (1) Remove the helmet mount from the carrying case. Refer to Figure 2.10. for helmet mount features.

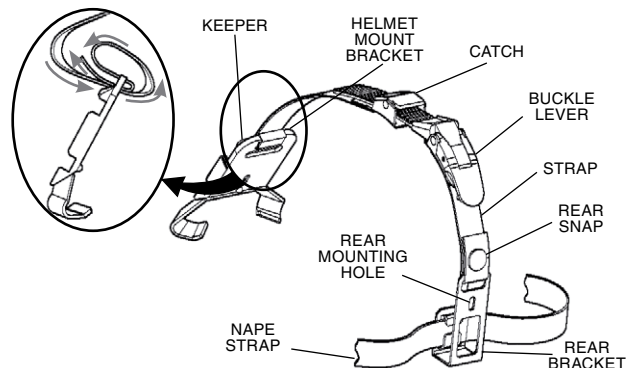

FIGURE 2.10. INSTALLATION OF HELMET MOUNT

- (2) Press the release (Figure 2.11.) to remove the mount from the helmet mount bracket.
- (3) Make sure the strap is laced onto the helmet mount bracket as shown in Figure 2.11.
- (4) With catch (see Figure 2.11.) in forward most position, place the strap over the top of the helmet center (see Figure 2.12).

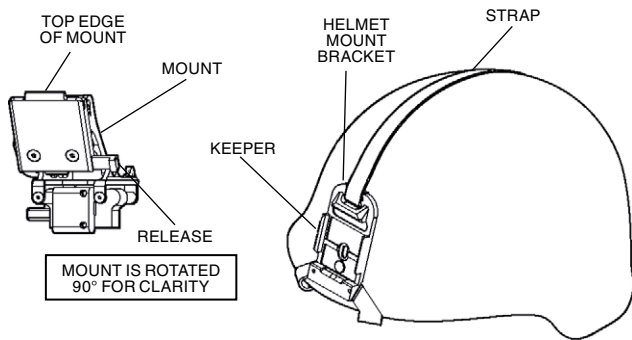

FIGURE 2.11. HELMET MOUNT

(5) Hook the rear bracket (see Figure 2.11.) on the center of the back of the helmet and lay the strap with helmet mount bracket over the top of the helmet.

(6) Hook the helmet mount bracket in the center of the front lip of the helmet and hold it in place (see Figure 2.12.).

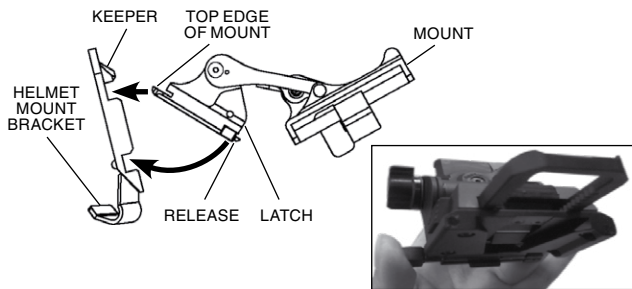

FIGURE 2.12. REASSEMBLY OF HELMET MOUNT

(7) With the buckle lever open, take up the slack in the strap using the catch. Close the buckle lever.

- (8) Disengage the nape strap latch on the left side of nape strap.
- (9) Don the helmet. Do not fasten the helmet chinstrap.
- (10) Engage the nape strap at the nape strap latch. Tension the nape strap for a stable fit, then install and tension the helmet chinstrap. The brow of the helmet should be parallel to the ground and the helmet stable on the head.
- (11) Insert the top edge of the mount under the keeper on the helmet mount bracket and rotate downward until the latch engages (see Figure 2.12.). To release the mount from the helmet bracket, press the release and pull forward and down.

2.4. OPERATING PROCEDURES

This section contains operating procedures for using the NVG as hand-held, head mounted, helmet mounted goggles. Prior to operating the goggles, make certain that all the steps in 2.3.3., Assembly and Preparation for Use, have been read and performed.

2.4.1. HAND-HELD OPERATION

Operate the goggles only under darkened conditions or use the objective lens cap to cover the objective lens for daylight conditions.

- (1) Ensure that the battery is installed per paragraph 2.3.2.
- (2) Turn the power switch to ON.



FIGURE 2.13. HAND-HELD OPERATION

NOTE

The sharpest image will be observed only when the objective lens and eyepiece lens are properly focused.

- (3) Rotate the diopter adjustment for the clearest view of the image intensifier screen.
- (4) Focus the objective lens while observing an object until the sharpest image is obtained.

2.4.2. HEAD MOUNTED OPERATION

Perform the following procedures for head mounted operation.

CAUTION

Operate the goggles only under darkened conditions or use the lens cap to cover the objective lens for daylight conditions.

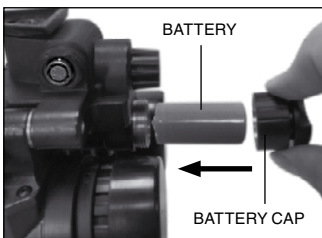

FIGURE 2.14. INSTALLATION OF BATTERY

- (1) Ensure that battery is installed per paragraph 2.3.2.
- (2) Don the headmount per instructions in paragraph 2.3.4.

NOTE

To make it easier to align the goggles, eyecup, and eyepiece lens to the eye, depress the eye relief adjustment and slide the headmount socket all the way forward before attaching the goggles.

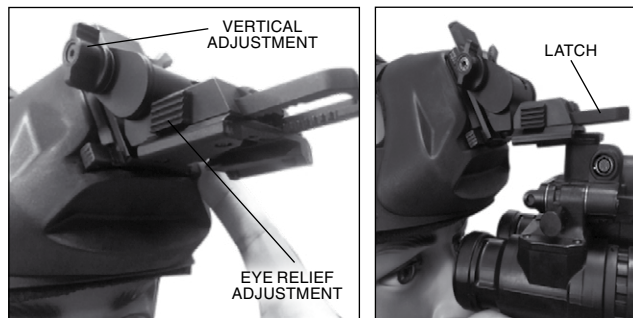

FIGURE 2.15. HEADMOUNT/HELMET MOUNT OPERATION

- (3) Align the headmount/helmet mount latch to the headmount socket (Figure 2.15.). Insert the Helmet Fixture into the Socket of the mount.
- (4) Set your eye relief by depressing the eye relief adjustment (Figure 2.15.) and move the goggles back toward your eye until the eyecup comfortably seals around the eye.
- (5) Turn the goggles ON.
- (6) Readjust the vertical adjustment (Figure 2.15.) of the head-mount until the goggles is properly aligned with your eye.

NOTE

The sharpest image will be observed only when the objective lens and eyepiece lens are properly focused.

- (7) Rotate the diopter adjustment for the clearest view of the image intensifier screen.

NOTE

Any readjustment of eye relief requires readjustment of the diopter.

- (8) Adjust the eye relief distance by pressing the eye relief adjustment and sliding goggles fore or aft to obtain a full field of view of the image. Reset the diopter adjustment for best image.

(9) Adjust the objective lens focus (Figure 2.1.) while observing an object until the sharpest image is obtained.

(10) In order to adjust the interpupillary adjustment to be in line with the distance between your eyes. Use the side knobs as illustrated in Figure 2.16.

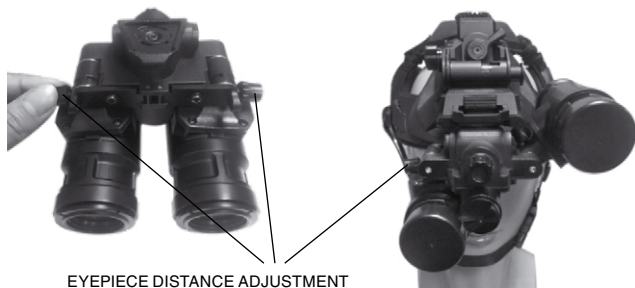

FIGURE 2.16. INTERPUPILLARY ADJUSTMENT

(11) When you flip the NVGs up over the Headmount the NVGs will automatically power off. When you flip the NVGs down into viewing position. The NVGs will power back up automatically.

2.4.3. HELMET MOUNTED OPERATION

CAUTION

Take some precaution when using/handling the helmet mount. Most damage occurs when the helmet mount is left on the helmet when not needed for immediate use. Observe the following cautions to significantly extend the useful life of the helmet mount.

CAUTION

- Do not use excessive force when changing the up/down position of the NVG.
- Do not drop or throw the helmet with the helmet mount attached to it.
- With the goggles in the flipped up position, do not flick the

goggles down by shaking the helmet. This places significant stress on the helmet mount.

- **All Other Services** — Return the helmet and the helmet mount to unit maintenance for direct mounting of the bracket via the helmet screws.

Perform the following procedures for helmet mounted operation.

NOTE

The helmet mount provides two positions for the user to position the NVG. The flipped down position allows the user to position the NVG directly in front of the eyes. The helmet mount also allows the user to rotate the NVG to a flipped up position when the NVG is not needed for immediate use. Both the flipped down and the flipped up positions have a positive stop which assures the user that the NVG is in the correct position.

- (1) Ensure that the battery are installed per paragraph 2.3.2.
- (2) Don the helmet mount per instructions in paragraph 2.3.5.
- (3) Place the goggles in the socket of the helmet mount.

Set your eye relief by depressing the side buttons (or press down on side lever on metal mount) (see Figure 2.17.) and carefully move the goggles fore or aft until the eyecup comfortably seals around the eye. Readjust the helmet straps as required for vertical adjustment.

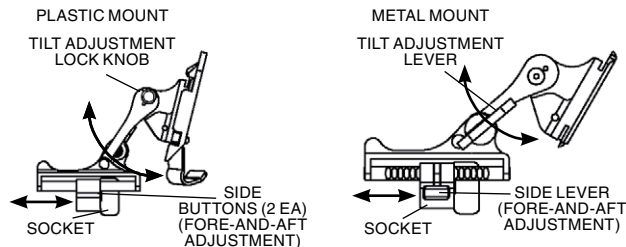

FIGURE 2.17. TILT AND FLIP-UP ASSEMBLY MECHANISMS

- (4) Turn power switch to ON. Adjust the tilt by using the tilt adjustment lock knob (or tilt adjustment lever on metal mount) (Figure 2.17.) until you obtain a comfortable viewing angle.

NOTE

The sharpest image will be observed only when the objective lens and eyepiece lens are properly focused.

- (5) Rotate the diopter adjustment for the clearest view of the image intensifier screen.

NOTE

Any readjustment of eye relief requires readjustment of the diopter.

- (6) Adjust the eye relief distance by depressing the side buttons (Figure 2.17.) (or press down on side lever on metal mount) and sliding goggles fore or aft to obtain a full field-of-view of the image. Reset the diopter adjustment for best image.
- (7) Adjust the objective lens focus (Figure 2.1.) while observing an object until the sharpest image is obtained.
- (8) In order to adjust the interpupillary adjustment to be in line with the distance between your eyes. Use the side knobs as illustrated in Figure 2.18.



FIGURE 2.18. INTERPUPILLARY ADJUSTMENT

- (9) To flip up, grasp the helmet tilt and flip-up assembly and rotate upward and rearward until the latch is firmly engaged.
- (10) To flip down, grasp the helmet tilt and flip-up assembly and rotate downward and forward until the latch is firmly engaged.
- (11) The NVG will turn back on automatically.

2.4.3.1. Eyepiece Distance Adjustment

In certain circumstances you would want use only One Eye to look through the NVG. Be it to retain your natural night vision in your eye when conducting dynamic maneuvers when you have to transition between dark and lit environments. Or to look through a sight which is affixed to your weapon.

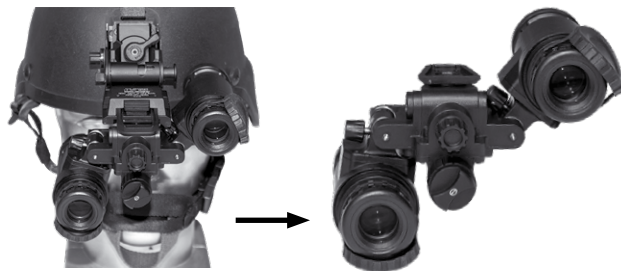

FIGURE 2.19. FLIPPING ONE EYEPiece OUT OF VIEW

- (1) Select the eyepiece you would like to move out of the field of view with the hand that is on the same side as the eyepiece.
- (2) Gently push it upwards with your hand so that it locks in position.
- (3) Your flipped up to the side eyepiece will turn off automatically in order to prevent light bleed from the eyepiece.
- (4) Conduct your maneuver as normal.
- (5) By lowering the previously flipped up to the side eyepiece, the eyepiece will power on again.

2.4.4. IR SOURCE OPERATIONS

WARNING

The IR source is a light that is invisible to the unaided eye for use during conditions of extreme darkness. However, the light from the IR source can be detected by the enemy using night vision devices.

NOTE

The purpose of the IR source is for viewing at close distances up to 3 meters when additional illumination is needed.

(1) Turn the power switch knob and rotate clockwise to the IR position. With the goggles held to the eye, observe that a red light appears in the eyepiece. This indicates that the IR source is operating.

(2) Auto Mode

The automatic mode is different from the "IR" mode, and the automatic mode starts the environment detection sensor. It can detect environmental luminance in real time and work with reference to illumination control system. Under extremely low or extremely dark environment, The system will automatically turn on infrared auxiliary lighting, and when the environmental illumination can meet normal observation, The system automatically turns off "IR", and when the ambient illumination reaches 40–100 Lux, The whole system is automatically shut down to protect the photosensitive core components from damage by strong light.

2.4.4.1. Auxiliary Battery Installation (optional)

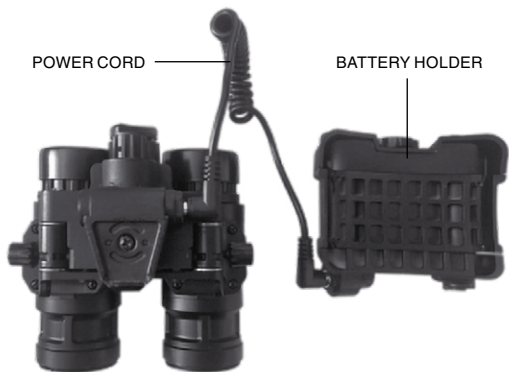

FIGURE 2.20. AUXILIARY BATTERY INSTALLATION

- (1) Install (4) CR123 batteries into the battery holder.
- (2) Attach the battery holder to the rear of the helmet or headgear.
- (3) Run the power cord from the battery holder to the NVG.
- (4) Plug the power cord into the NVG (Figure 2.21).

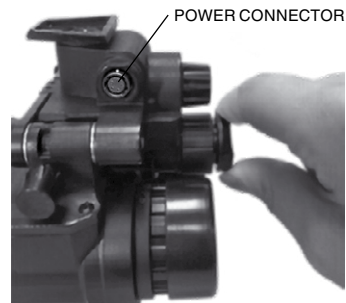

FIGURE 2.21. POWER CONNECTOR

- (5) Turn the NVG on.

2.4.5. PREPARATION FOR STORAGE

- (1) Shutdown. Perform the following procedures to shut down the goggles.
 - (a) Turn the goggles power switch to the OFF position.
 - (b) Remove the goggles from the headmount or helmet mount.

WARNING

Do not carry batteries in pockets containing metal objects such as coins, keys, etc. Metal objects can cause the batteries to short circuit and become very hot.

- (2) Packaging after use.
 - (a) Remove battery cap and remove battery.
 - (b) Inspect the battery housing for corrosion or moisture. Clean and dry if necessary.
 - (c) Replace the battery cap.

(d) Install objective lens cap.

NOTE

• **Prior to placing NVG into carrying case, ensure NVG and case are free of dirt, dust, and moisture.**

• **The goggles and helmet mount should not be left on the helmet when the helmet is removed.**

(e) Place the goggles into the shallow pocket of the carrying case.

(f) Place the carrying case into the shipping and storage case.

(g) Return to storage area.

2.5. OPERATION UNDER UNUSUAL CONDITIONS

2.5.1. OPERATION IN DUSTY OR SANDY AREAS

CAUTION

Operation in dusty or sandy areas can pit and scratch the optical elements and damage the mechanical components unless the precautions given below are observed.

(1) Avoid pointing the goggles into the wind unless necessary for operation.

(2) Keep the carrying case closed unless removing or replacing items.

(3) Ensure that all dust and sand is removed from the NVG and carrying case after operation.

2.5.2. OPERATION IN RAINY OR HUMID CONDITIONS

CAUTION

Operation in rainy or humid conditions can cause corrosion and deterioration of the NVG unless the precautions given below are observed.

(1) Keep the carrying case, and shipping and storage case closed unless removing or replacing items.

(2) Dry the goggles, mounts, and accessories after exposure to rain or high humidity and before storage. This will prevent mildew from forming in the case.

(3) Do not store goggles in a wet carrying case or a wet shipping and storage case.

2.5.3. OPERATION IN SALT WATER AREAS

After exposure to salt water, clean the NVG (paragraph 3.3.1.).

2.5.4. OPERATION IN NUCLEAR, BIOLOGICAL AND CHEMICAL (NBC) ENVIRONMENTS

WARNING

Do not use contaminated eyecup. They must be replaced.

(1) Decontamination — Wear a protective mask while using NVG after decontamination process.

(2) Hardness — Do not use DS-2 for decontaminating the NVG. To decontaminate, use 5% sodium hypochlorite and rinse with hot (158°F) soapy water.

CHAPTER 3

MAINTENANCE INSTRUCTIONS

3.1. LUBRICATION INSTRUCTIONS

No lubrication is required.

3.2. TROUBLESHOOTING PROCEDURES

3.2.1. TROUBLESHOOTING

Table 3.1. lists common malfunctions that you may find with your equipment. Perform the tests, inspections and corrective actions in the order they appear in the table.

This table cannot list all the malfunctions that may occur, all the tests and inspections needed to find the fault, or all the corrective actions needed to correct the fault. If the equipment malfunction is not listed or actions listed do not correct the fault, notify your maintainer.

TABLE 3.1. OPERATOR'S TROUBLESHOOTING.

MALFUNCTION	TEST OR INSPECTION	CORRECTIVE ACTION
1. Goggles fails to activate.	Visual.	Turn power switch to OFF position and then ON.
2. IR source fails to activate.	Check for defective, missing or improperly installed battery.	Replace battery or install correctly.
3. IR source indicator fails to activate.	In a dark location with system turned on, activate IR source. Visually check IR source operation; scene should brighten.	If IR source still fails to activate, refer to higher level of maintenance.
4. Poor image quality.	Visual.	Refer to higher level of maintenance.
5. Light visible around eyecup.	Check objective lens or eyepiece lens focus.	Refocus.
	Check for fogging or dirt on objective lens or eyepiece lens.	Clean lens surfaces per paragraph 3.2.
	Check eye relief distance.	Readjust for proper eye relief distance.
	Check eyecup for resiliency.	If eyecup is defective, refer to higher level of maintenance.
6. Diopter adjustment cannot be made.	Check to see if the diopter adjustment is bent or broken.	If damaged, refer to higher level of maintenance.

MALFUNCTION	TEST OR INSPECTION	CORRECTIVE ACTION
7. Battery cap difficult to open.	Visually inspect for the presence of an o-ring. Check for damaged battery cap.	If o-ring is missing, refer to higher level of maintenance. If damaged, refer to higher level of maintenance.
8. Head straps cannot be tightened.	Check for defective buckles, fasteners or straps.	If damaged, refer to higher level of maintenance.
9. Headmount or helmet mount socket and headmount/ helmet mount adapter latch does not catch.	Check socket or latch for dirt. Check socket or latch for damage.	Clean socket and latch. If damaged, return either headmount or helmet mount socket and headmount/ helmet mount adapter to higher level of maintenance.
10. Helmet mount will not tighten to helmet.	Inspect mounting hardware for damage.	If damaged, refer to higher level of maintenance.
11. If damaged, refer to higher level of maintenance.	Visual.	Refer to higher level of maintenance.

MALFUNCTION	TEST OR INSPECTION	CORRECTIVE ACTION
12. Goggles does not cut off when exposed to high light.	Visual. Perform the following test under daylight or bright room light (not fluorescent light). Place the objective lens cap on the objective lens. Turn goggles ON and observe that it cuts off within 70 ±30 seconds after energized. Turn goggles OFF and then ON to reenergize goggles.	If damaged, refer to higher level of maintenance.

3.3. OPERATOR'S MAINTENANCE PROCEDURES

3.3.1. CLEANING THE NVG

CAUTION

- **The goggles is a precision electro-optical instrument and must be handled carefully.**
- **Do not scratch the external lens surfaces or touch them with your fingers.**

Clean goggles with water if necessary and dry thoroughly. Clean lenses with lens paper.



For customer service and technical support, please contact

American Technologies Network Corp.

1341 San Mateo Avenue, South San Francisco, CA 94080

phone: 800-910-2862, 650-989-5100

www.atncorp.com